

# CORRIDOR OF LIGHT

ARLINGTON, VIRGINIA

North Lynn Street Public Art Initiative



## Participants

### ARTIST SELECTION / ART PROPOSAL REVIEW PANEL

David Goodman  
Arlington County, Department of Environmental Services, Transportation Planning

Tom Hutchings  
Arlington County, Department of Environmental Services, Transportation Planning

Martha Jackson-Jarvis  
Artist

Terri Prell  
Arlington Commission for the Arts/Public Art Committee member

Kathleen Webb  
The JBG Companies

Cecilia Cassidy  
Rosslyn Renaissance/Rosslyn Business Improvement District

### ARLINGTON COMMISSION FOR THE ARTS

John Seal

Suzanne Bethel

Rene Costales

Angela Fox

Wes MacAdam

Monique O'Grady

Vanessa Piccorossi  
Chair, Public Art Committee

Gail Raiman

Steve Rosenberg

Susan Soroko

Dana Theus

Vicki Walker

Kimberly Ward

### Public Art Committee

Jonathan Fitch

Brian Harner

Rick Wall

### ARLINGTON COUNTY BOARD

J. Walter Tejada

Barbara Favola

Jay Fisette

Chris Zimmerman

Mary Hynes

### CONSULTANTS

Todd Bressi  
Brown & Keener Bressi

Meridith McKinley  
Via Partnership

Toole Design Group

### ARLINGTON COUNTY GOVERNMENT STAFF

Ron Carlee  
Arlington County Manager

Gabriela Acurio  
Assistant County Manager

Dinesh Tiwari  
Department of Parks, Recreation, and Cultural Resources, Department Director

Norma Kaplan  
Department of Parks, Recreation, and Cultural Resources, Cultural Affairs Division Chief

Angela Adams  
Department of Parks, Recreation, and Cultural Resources, Public Art Program

Welmoed Laanstra  
Department of Parks, Recreation, and Cultural Resources, Public Art Program

Brooks Barwell  
Department of Parks, Recreation, and Cultural Resources, Public Art Program

Caroline Danforth  
Department of Parks, Recreation, and Cultural Resources, Public Art Program

Rich Dooley  
Community Planning, Housing and Development, Current Planning

Anthony Fusarelli  
Community Planning, Housing and Development, Comprehensive Planning

Lorrie Pearson  
Community Planning, Housing and Development, Current Planning

Jill Griffin  
Arlington Economic Development

Scott McPartlin  
Department of Parks, Recreation, and Cultural Resources, Park Planning & Design

David Miller  
Department of Parks, Recreation, and Cultural Resources, Park Planning & Design

Bridget Obikoya  
Department of Environmental Services, Traffic Engineering

### ROSSLYN RENAISSANCE

Lucia de Cordre  
Urban Design Project Manager, Rosslyn Renaissance/Rosslyn BID

### THE JBG COMPANIES

Andrew Vanhorn

Michael Thorne

Holly Hartman

# CORRIDOR OF LIGHT

ARLINGTON, VIRGINIA

## CLIFF GARTEN STUDIO

Cliff Garten  
Artist, Principal

Jack Hartley  
Studio Manager

Jonathan Butt  
Project Designer

Deborah Fuentes  
Design Support

1315 Preston Way  
Venice, CA 90291  
t. (310) 392-2060  
e. cg@cliffgartenstudio.com  
http://www.cliffgartenstudio.com

Copyright 2008 Cliff Garten & Associates Inc., DBA: Cliff Garten Studio

North Lynn Street Public Art Initiative

## Table of Contents

|                                 |    |
|---------------------------------|----|
| Rosslyn .....                   | 5  |
| North Lynn Street               |    |
| Areas of Emphasis .....         | 6  |
| Project Elements .....          | 8  |
| A Tradition of Sculpture .....  | 10 |
| New Monumentality .....         | 12 |
| Corridor of Light               |    |
| Urban Identity .....            | 14 |
| Street Ensemble .....           | 16 |
| Esplanade .....                 | 18 |
| Urban Corridor .....            | 20 |
| Street Ensemble                 |    |
| Materials and Lighting .....    | 26 |
| Orchestrating Color .....       | 28 |
| Structure and Maintenance ..... | 30 |
| Street Furnishings              |    |
| Luminous Bike Rack .....        | 32 |
| Luminous Bench .....            | 33 |
| Public Art/ Public Life .....   | 34 |
| Lighting Fixtures .....         | 36 |

## Rosslyn A New Presence for Lynn Street

Rosslyn is a neighborhood that has been subject to the economic growth and urban expansion of the Washington DC area. With its buzz of commerce it has the feeling of a condensed version of a much larger city. The demand for office

space and the expanding concerns of the District of Columbia are likely to effect an architectural environment that will continue to increase in scale and to challenge Rosslyn's pedestrian environment.

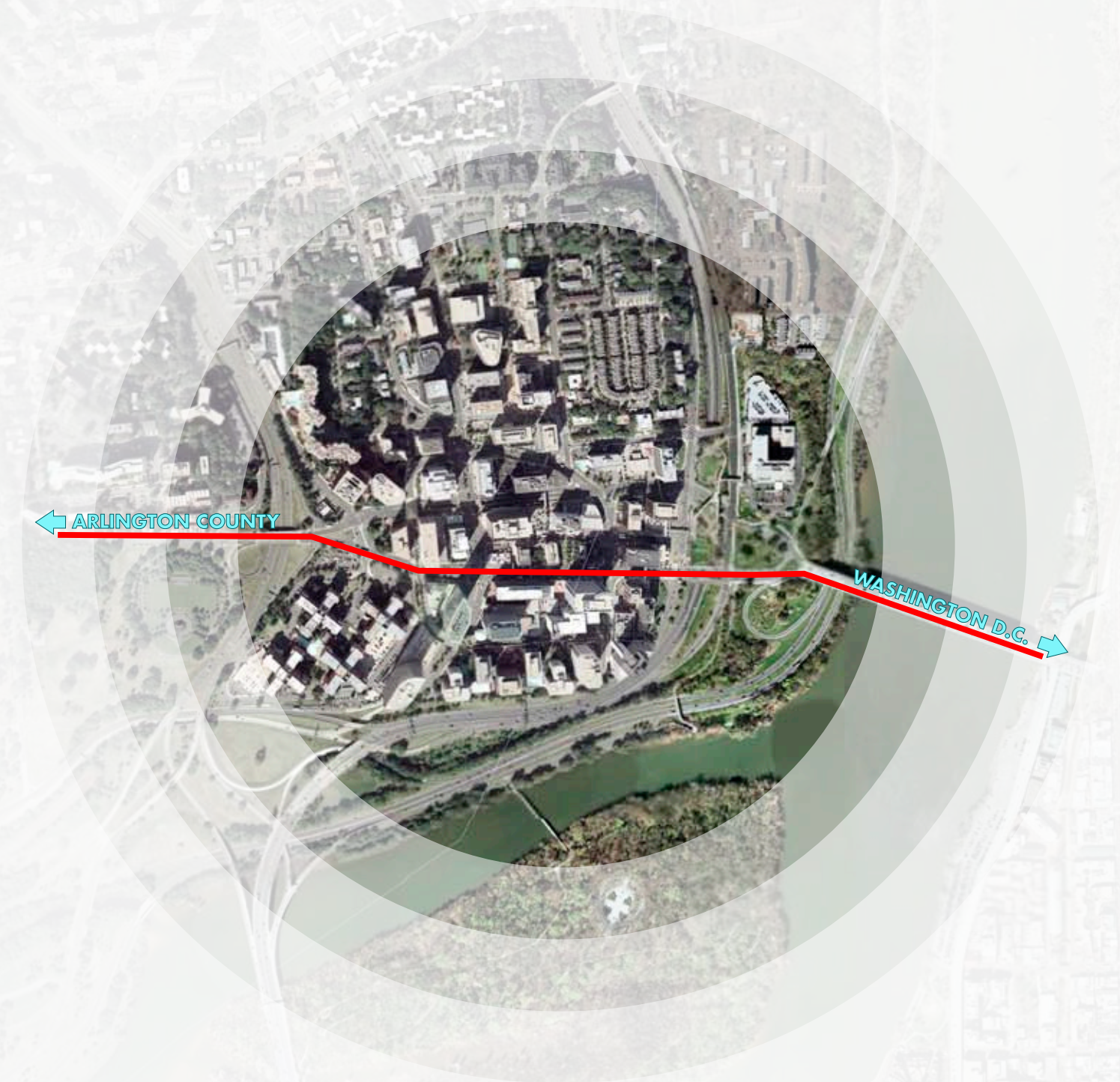

# North Lynn Street Areas of Emphasis

The North Lynn Street corridor needs public art to keep pace with the changing scale of the urban environment and to establish a memorable public space. As a connection to Key Bridge and Meade Street Bridge, Lynn Street is a commercial, transportation, and pedestrian artery in Rosslyn. The I-66 overpass bridge, soon to be refurbished as part of Arlington

County's Esplanade project, will enhance the entry from the District of Columbia adjacent to Key Bridge. In addition, Meade Street Bridge, adjacent to the Iwo Jima Memorial, is also slated for renovation. These two bridges are anchors at the north and south ends of the street and mark entries from Arlington to the south and from Washington D.C. to the north.

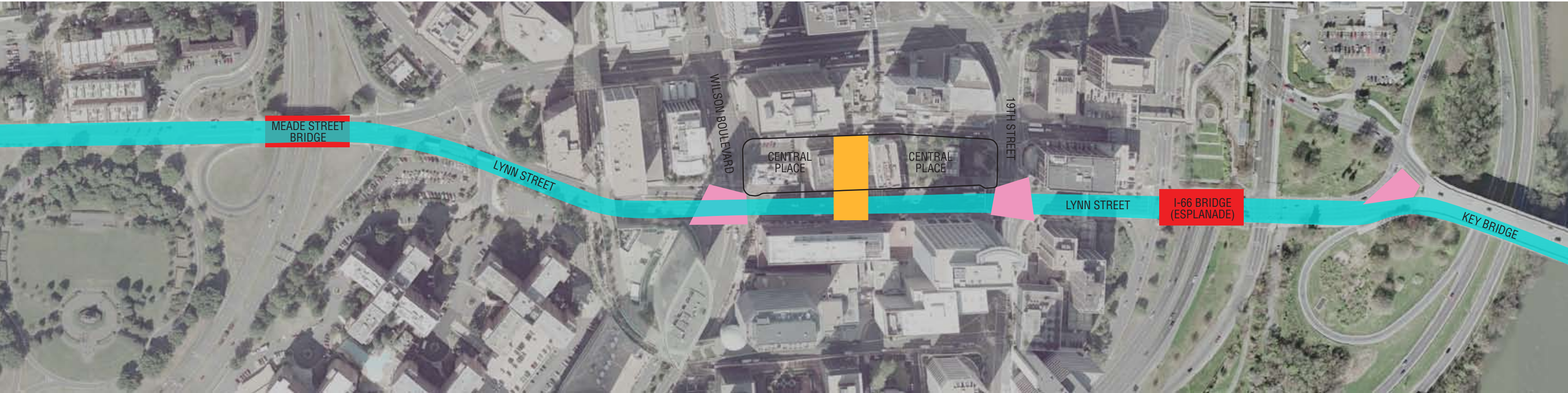

 Lynn Street

 Bridges

 Intersections

 Central Place Plaza\*

\* The JBG Companies are erecting two towers and creating a public plaza which will reshape Lynn Street between 19th Street and Wilson Boulevard. This development will help to transform Lynn Street into an urban center. It creates the opportunity to address Lynn Street as a destination unto itself. Public art will mark this vibrant residential and commercial place.

## North Lynn Street Project Elements

The Corridor of Light, a synthesis of public sculpture and lighting infrastructure, embraces and defines Rosslyn's urbanity. Illuminated sculptures of different scales appear at significant junctures along the corridor to create a series of linked points from Key Bridge to Meade Street Bridge.

The typical pedestrian light is integrated into this ensemble which is an urban event comprised of a series of public sculptures. The periodic placement of the sculptures gives rhythm to traveling Lynn Street and a comprehensive urban vision to the corridor.

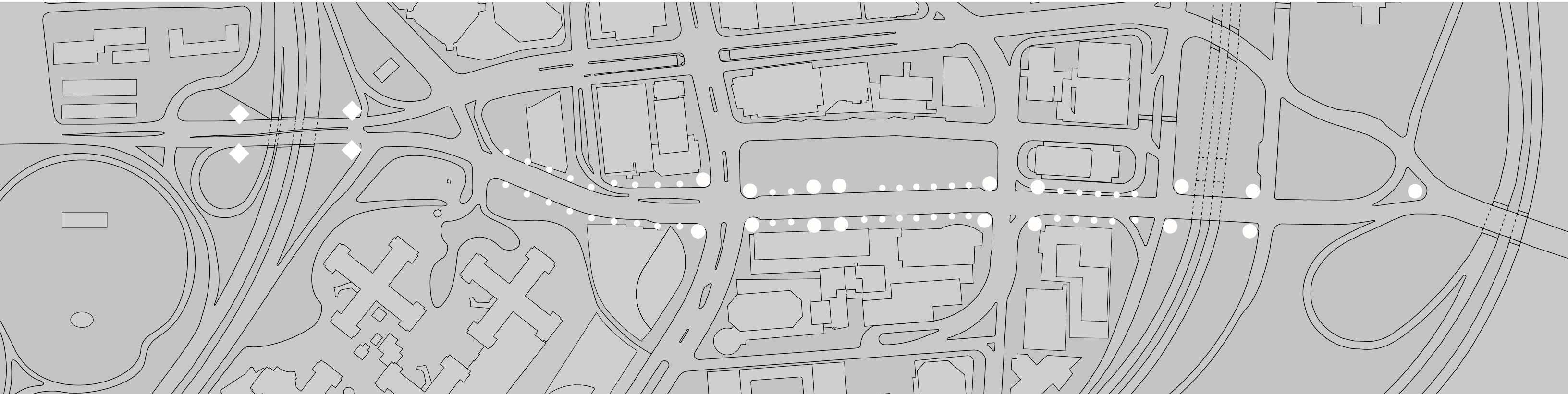

Street Lanterns



26' Luminous Body Sculptures



21' Luminous Body Sculptures

The District of Columbia and its surroundings play host to a rich tradition of commemorative sculpture. From the Washington Monument on the National Mall to the Iwo Jima Memorial in Arlington, Virginia, the region is defined by the grand classicisms of 19th and 20th century America. Often built from bronze and stone, the forms that populate the nation's capital are marked by a material gravitas in accord with the many events they immortalize. Rosslyn is bracketed by these traditions.



The development of a family of sculptures that would create a memorable and enjoyable urban environment sprang from past work by Cliff Garten Studio (CGS) where illuminated forms are used to mark an urban district.\*

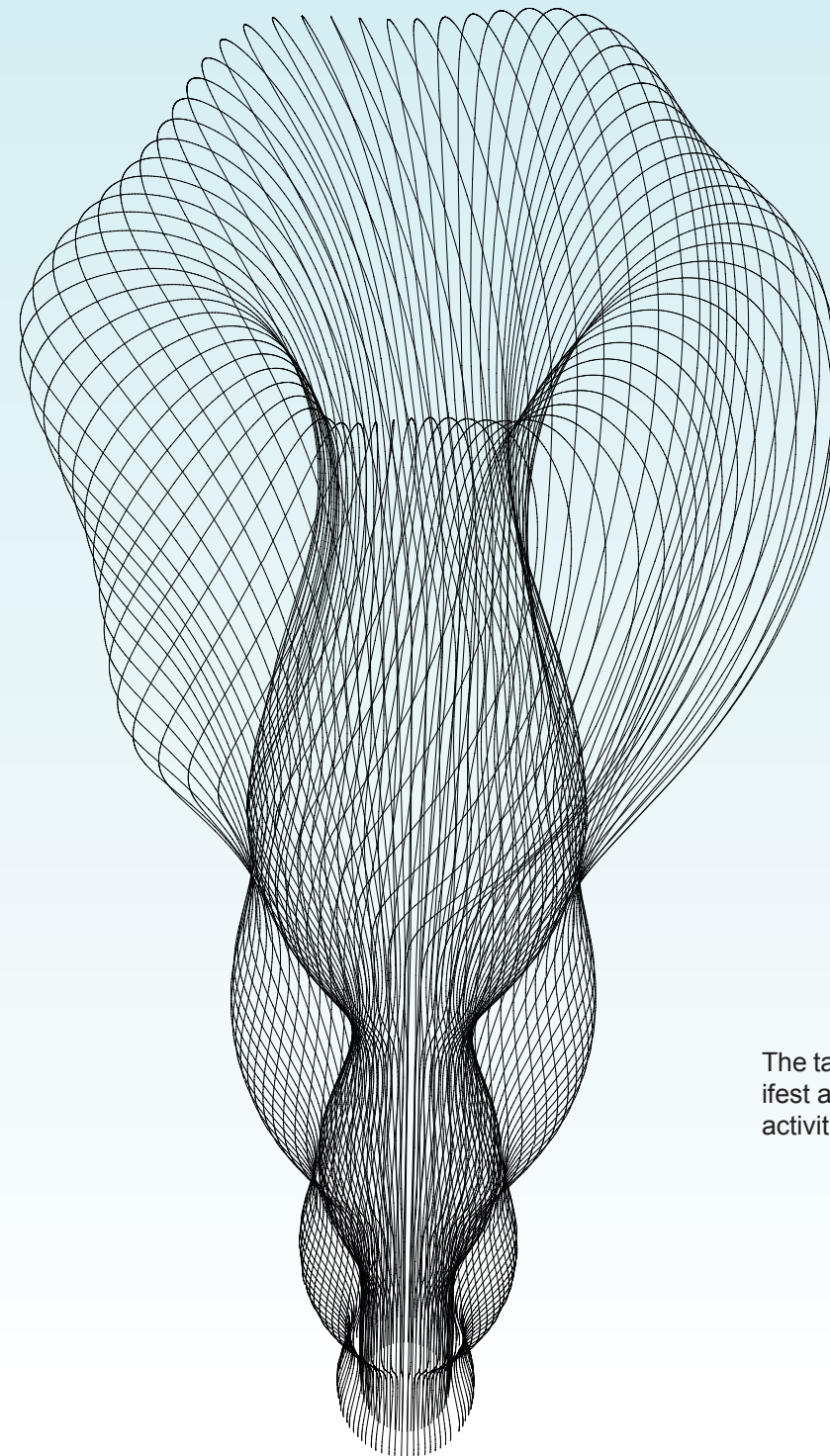

\* Light Column (18')  
Sharon Road West Light Rail Station  
Charlotte, North Carolina  
Copyright 2007  
Cliff Garten Studio

When establishing Rosslyn's urban identity, it is possible to embrace Washington's monumentality in a way that represents Rosslyn's expansion as an urban center in the 21st century.



The task was to generate a type of object that would manifest a striking form and retain a physical openness to the activities of Lynn Street.

26' Luminous Body (stainless steel, bronze, LED lighting) marking the Lynn Street entrance to the plaza at Central Place- looking south

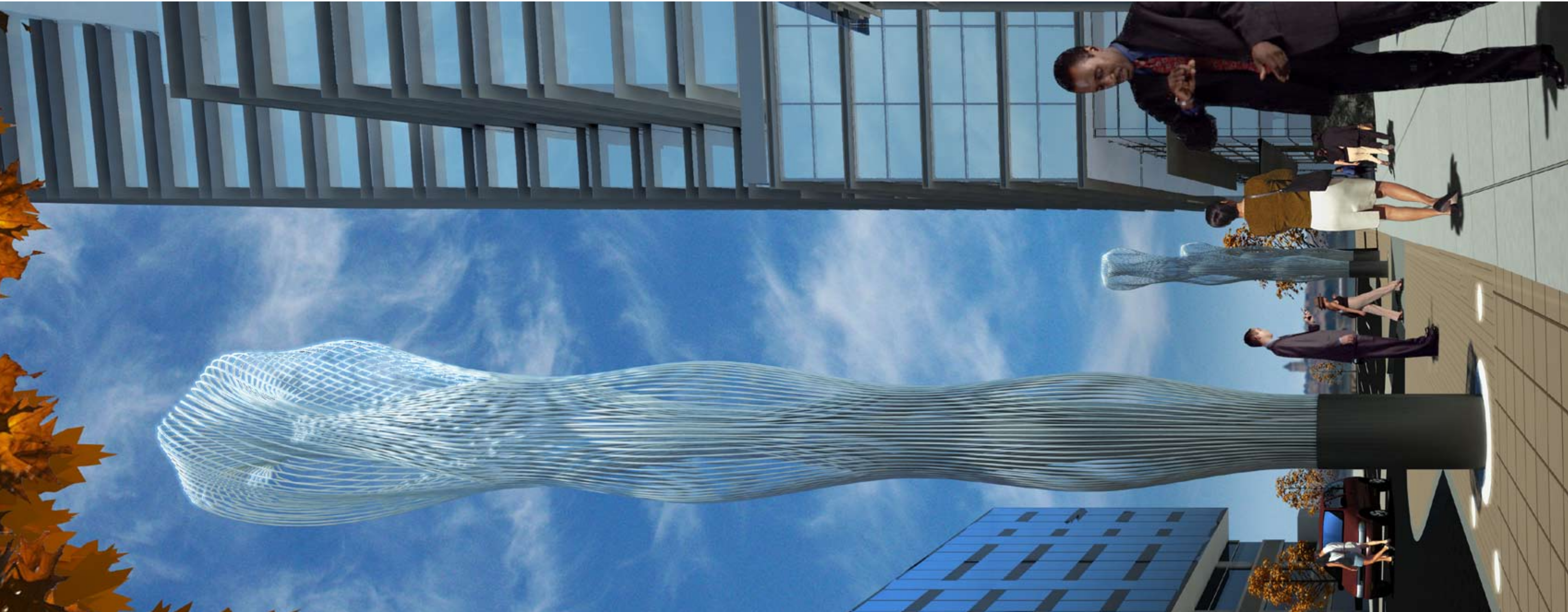

The *Luminous Body* sculptures parallel the verticality of neighboring architecture. They employ form and light to create a vibrant energy on Lynn St. In repetition they emphasize the gesture of a grand boulevard, creating urban continuity and linking Meade Street Bridge and the Esplanade.

The sculptures are monumental in scale yet intimate in character. They are defined by the open tracing of one volume residing within another. Like the Klein Bottle with no distinction between its interior and exterior surfaces, the *Luminous Bodies* turn in on themselves, creating a continuous transparent surface that can be filled with light.

They have a different presence during the day than they do during the night. During the day the slender rods which define their surfaces reflect sunlight that passes through the sculptures' volumetric layers. At night they are illuminated with colored LED lights.

26' Luminous Body (stainless steel, bronze, LED lighting) marking the Lynn Street entrance to the plaza at Central Place- looking north  
 16' Street Lantern (stainless steel, bronze, metal halide lighting) marking the Lynn Street corridor



What do we mean when we speak about urban identity? American cities often assume a *derrière garde* position whereby they adopt the image of a historicism that never was, to avoid the risk of having to imagine what could be. Conversely, this project will allow Rosslyn to invent a fresh perspective towards its streets and infrastructure. In contrast to the hierarchy and opacity of the monumental traditions that bookend the Rosslyn neighborhood, The *Corridor of Light* offers a transparent monumentality which opens to Lynn Street.

Perhaps the most important aspect of any street is its urban scale. Rosslyn is a neighborhood whose scale has taken it by surprise. Its burgeoning commerce and what will surely be a demand for more commercial space are challenging the pedestrian environment. While the community of public and private partnerships in Rosslyn would surely like to grow, this community just as surely desires to create a distinctive identity and a positive experience on its streets where public and private interests meet in the face of this rapid growth.

Rosslyn desires an urban identity that states its difference from its neighbors and its arrival as a new urban center amongst older traditions. In contrast to its neighbors, Rosslyn should assert a new monumentality and the possibility of a vibrant street life and a street with a distinctive image. The *Luminous Bodies* are monumental in scale, but possess a diaphanous quality that plays with sunlight during the day and with LED's at night, making the course of North Lynn Street an exciting district.

What engages the pedestrian at a fine-grained scale should also be evident to vehicles where the streets length is taken in at a rapid pace. Scale and repetition are essential to making an impression that one has arrived at a significant urban district. The *Luminous Bodies* have been developed as three different illuminated forms. Two illuminated types of street furnishings compliment the ensemble.



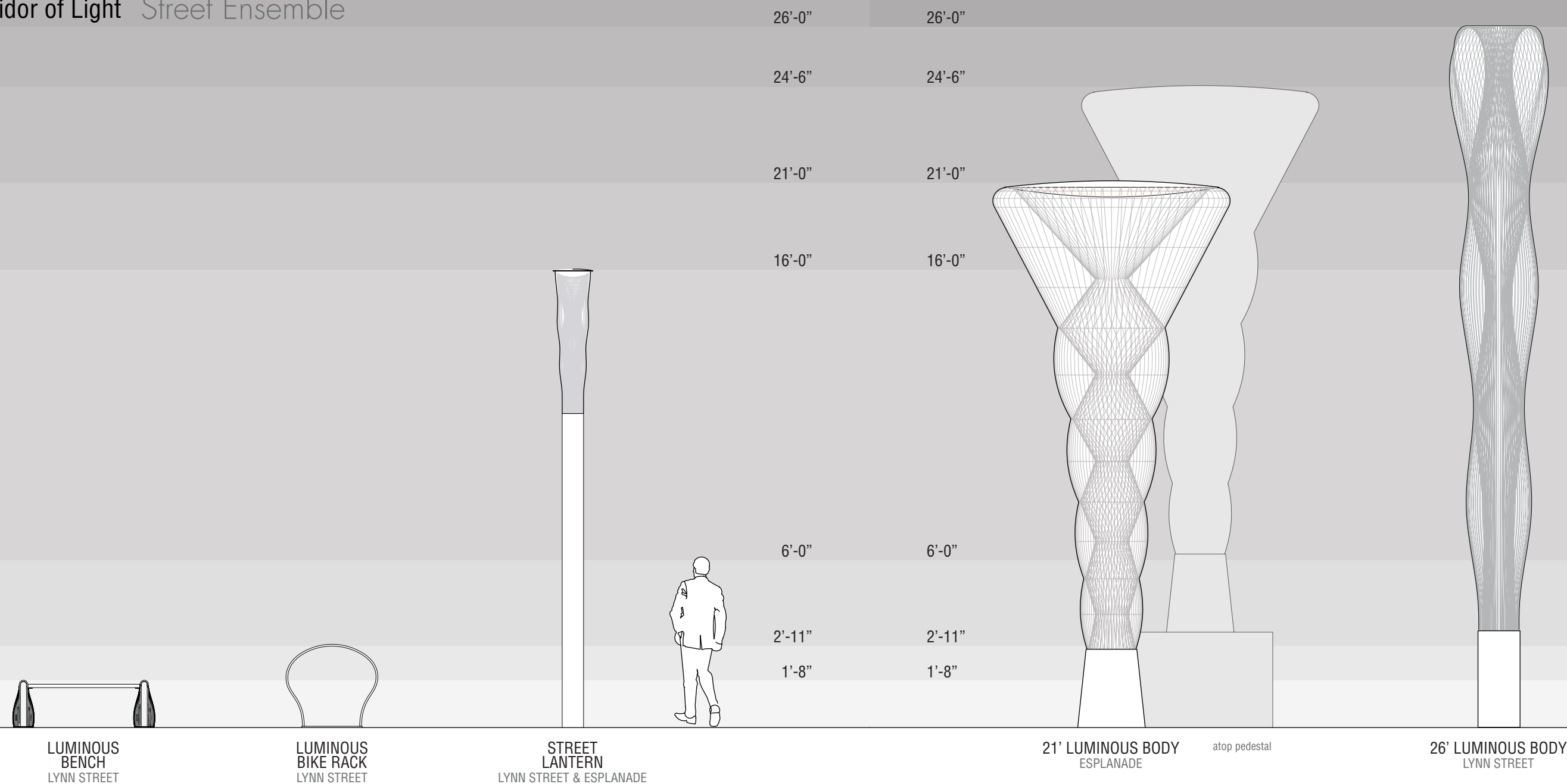

There are five types of illuminated sculptures, each with a different form and each operating at a different elevation.

The *Luminous Benches* and the *Luminous Bike Racks* are similar in scale to bollards. They illuminate a 2'-3' zone above the sidewalk and translate the form of the *Luminous Bodies* to the scale of the pedestrian.

The first order of sculpture is the *Street Lantern*. At 16' tall it is built to illuminate the sidewalks. The *Street Lanterns* are designed to replace the existing pedestrian lighting and to establish a series of sculptural lights that are part of the same family of forms which create a continuous corridor of light. These *Street Lanterns* will meet the foot candle requirements and the rigorous maintenance requirements of Arlington County.

The second order of sculptures is the *21' Luminous Body*. These sculptures mark the four corners of the Esplanade. These sculptures rest atop a concrete pedestal which is part of each bridge, lifting them 3' to 5' higher than the sidewalk, and topping them out at 24' to 26' in height. They adapt themselves to the bridges' structures and change our perception of these roadways from engineered structure to urban entrance.

The third order is the *26' Luminous Body*. These objects are found at the intersections of Lynn Street and Wilson Boulevard, Lynn Street and Central Place, and Lynn Street and 19th Street. Four *26' Luminous Bodies* frame each of these intersections. They operate at the scale of the street for the pedestrian and the motorist. Though these large sculptures hold their space against the architecture, their materiality is of a fine-grained nature and offers an intimate quality visible to the pedestrian.

# Esplanade A Photosensitive Response

21' Luminous Body (stainless steel, bronze, LED lighting) marking the corners of the Esplanade- looking north  
16' Street Lantern (stainless steel, bronze, metal halide lighting) marking the Lynn Street corridor



When marked by four 21' *Luminous Bodies*, the Esplanade and Meade Street Bridges will become memorable entry points for Rosslyn. The sculptures will be positioned on the ends of the two abutments of each bridge.

Cliff Garten Studio will work with the bridge engineer to design these concrete ends, raising the 21' tall sculptures 3'-5' above the sidewalk on each of the four concrete abutments.

The *Luminous Bodies* have a different presence during the day than they do during the night. During the day the slender rods which define their surfaces reflect sunlight that passes through the sculptures' volumetric layers. At night they are illuminated with colored LED lights.

Lynn Street- looking north



Esplanade roadway- looking south



The rhythm and cadence of the *Corridor of Light* is established by the scale and sequencing of the *Luminous Bodies* along Lynn Street. The series of illuminated sculptures will create a sense of arrival when entering or leaving the Rosslyn neighborhood from the Esplanade or Meade Street Bridge as well as a sense of continuity and arrival along the length

of the Lynn Street corridor. The following are video stills from a fly-through along Lynn Street produced by CGS. Fully programmable LED lights in each of the fixtures will allow infinite variation of colored light to occur over time along the *Corridor*. A light show can be programmed from one end of Lynn Street to the other.

Meade Street Bridge- looking north



Meade Street Bridge- from the roadway looking north

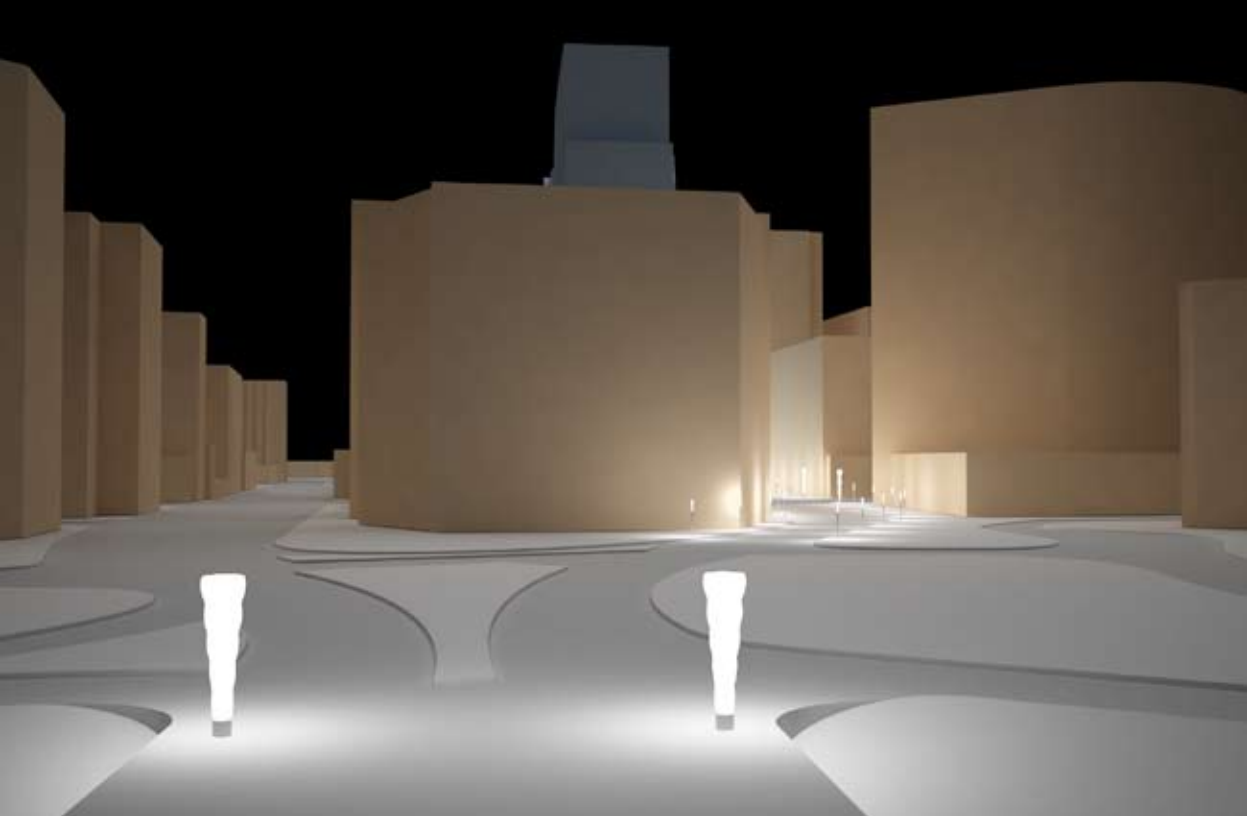

Lynn Street and Wilson Boulevard- looking north



Lynn Street- looking north from the intersection of Lynn Street and Wilson Boulevard



**MATERIALS:**

- A. 3/32" Formed Stainless Steel Rods
- B. 3/8" Formed Stainless Steel Rods
- C. 1/2" Formed Stainless Steel Rods
- D. 1-1/2" Stainless Steel Structure/ Power Feed
- E. 3/4" Formed Stainless Steel Rods
- F. Bronze
- G. Concrete Footing
- H. Parabolic Reflector
- I. Frosted Glass

**LIGHTING:**

- 1. 150W Metal Halide
- 2. LED Spot
- 3. LED In-grade Spot
- 4. LED Mini
- 5. LED Controller
- 6. LED Power Supply

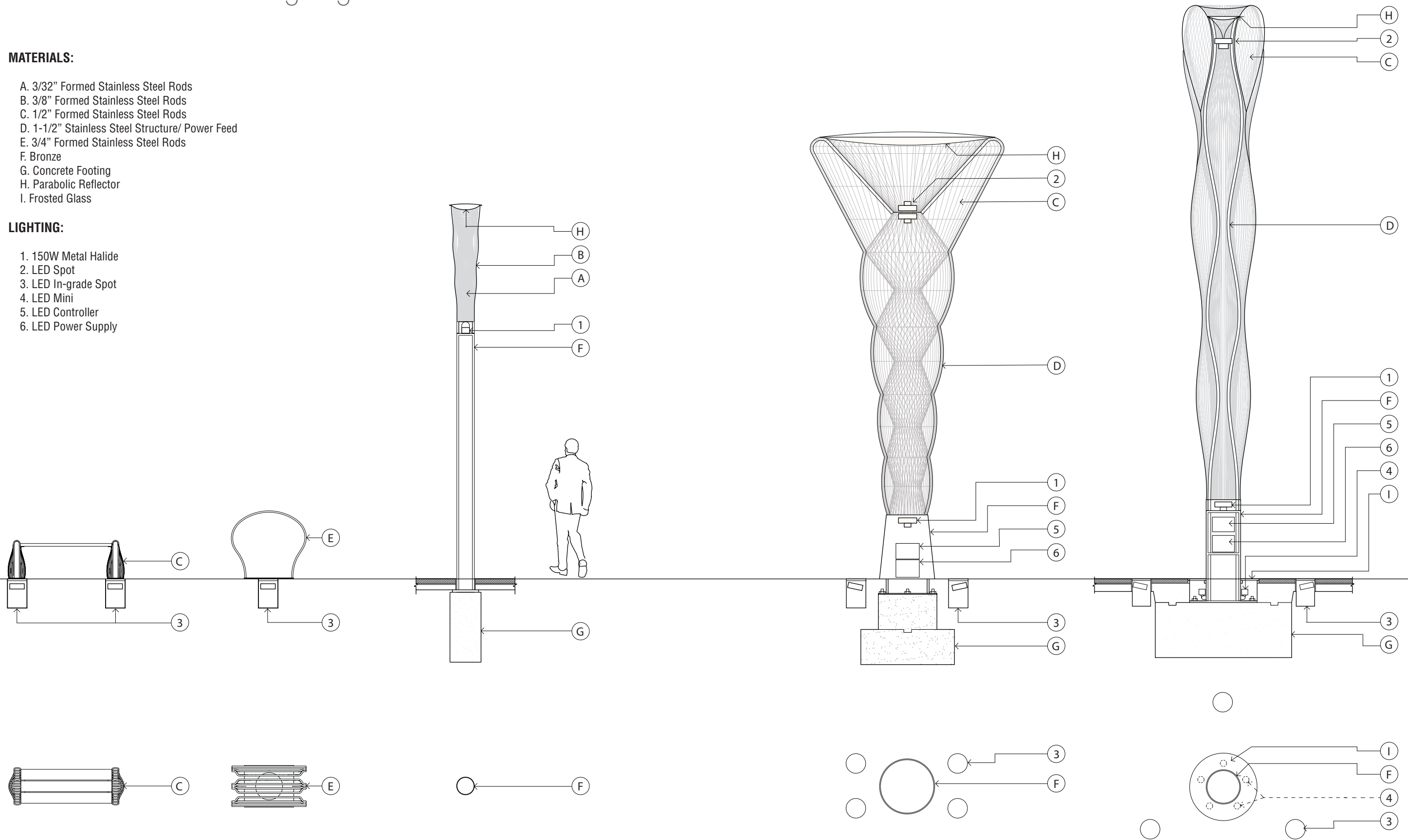

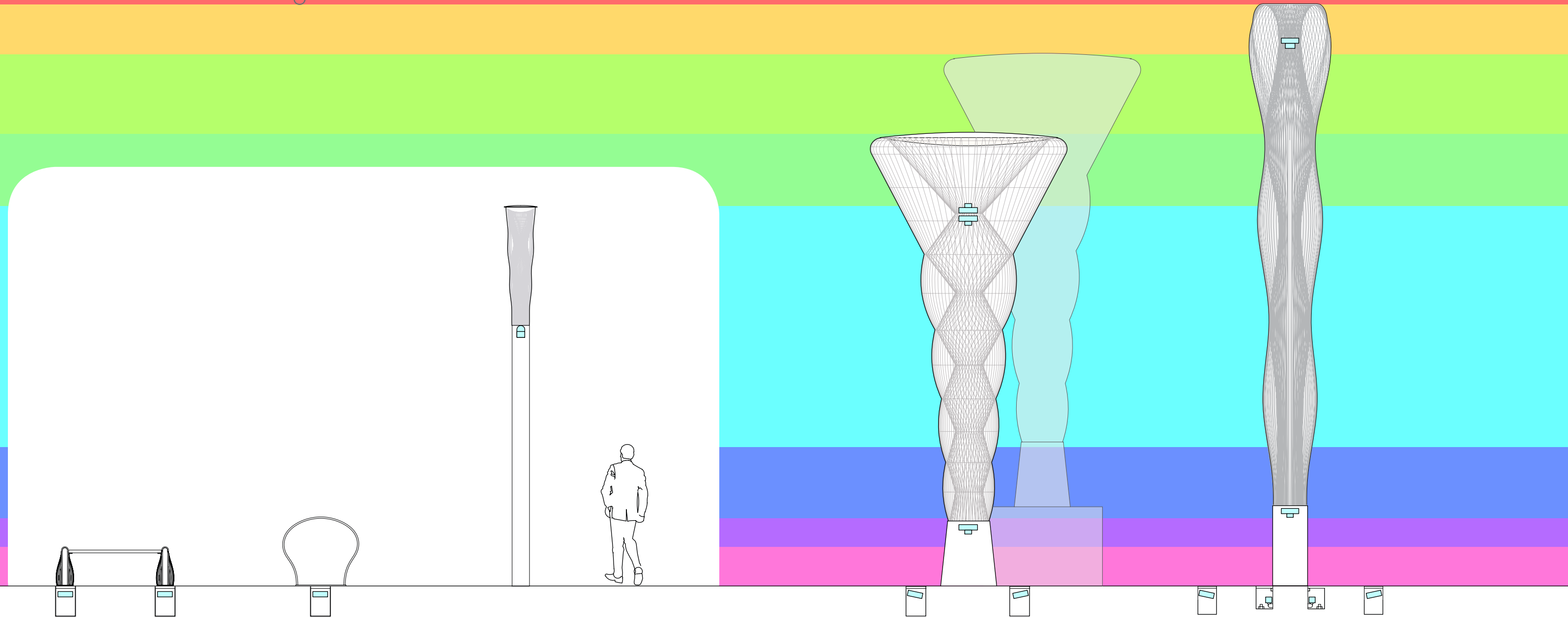

The Street Ensemble provides functional street lighting and celebratory urban lighting. Street lighting necessary for the pedestrian is provided by *Street Lanterns*. They create a visual ceiling at approximately 16' above the street, illuminating the space below to define and add warmth to the pedestrian experience.

The *Street Lanterns* use energy efficient HID lighting of approximately 150 watts, typical of Rosslyn's present standards in terms of color, energy efficiency, and maintenance requirements. Relamping is done as with any existing street fixture in Rosslyn. Additionally, this pedestrian space is populated with benches and bike racks. They are also self-illuminated (LED) for increased aesthetic and security benefits.

The 21' and 26' *Luminous Bodies* are grand urban gestures. They activate intersections, important public spaces, and bridge entries. The *Luminous Bodies* have integral light-emitting diode fixtures (LED). Two lamps are mounted internally, one shining up from the bottom and one shining down from the top. They illuminate the interior volume with light. Three in-ground lamps shine upward, bathing the exterior surfaces in a contrasting light. The 26' *Luminous Bodies* have three additional in-ground lamps mounted beneath an at-grade glass ring to create a glowing band of light around the base.

These LED fixtures offer fully programmable multi-color light displays. With this capability Rosslyn will be able to orchestrate any number of lighting programs for holidays or other special events. Sculptures may be synchronized to change color in unison or they may be sequenced to heighten the experience of moving along Lynn Street.

The LED fixtures are 25-40% more energy efficient than HID with 5 times the lamp life. Savings in energy and maintenance costs are significant. All but the top LED fixtures in the *Luminous Bodies* are accessible from the ground for relamping. Relamping the top fixtures is the same as for any large street light.

The diaphanous nature of the *Luminous Bodies*, *Street Lanterns*, and *Luminous Furnishings* belie the inherent physical strength of the sculptures. In the *Luminous Bodies* the formed stainless steel rods define both exterior and interior surfaces with continuously undulating volumes. The 3/8" and 1/2" stainless steel rods converge and are welded to stainless steel supports that integrate the rods for strength in torsion, bending, and compression. The stainless steel superstructure is structurally integrated into the bronze-sheathed stainless steel base of each sculpture which in turn is secured to a concrete foundation. The *Street Lanterns* are similarly conceived with 3/32" and 3/8" rods. They create a top lantern that rises from a bronze or stainless pipe. Finally, the *Luminous Benches* and *Luminous Bike Racks* use 1/2", and 3/4" formed stainless steel, applying

the vocabulary and language of the larger pieces to the most intimate pedestrian elements. The sculptures will stand up to the abuse of the street because they are made of stainless steel. Periodic cleaning of airborne debris may be required. However, the sculptures themselves require little maintenance and there is no continuous surface to mar or graffiti.

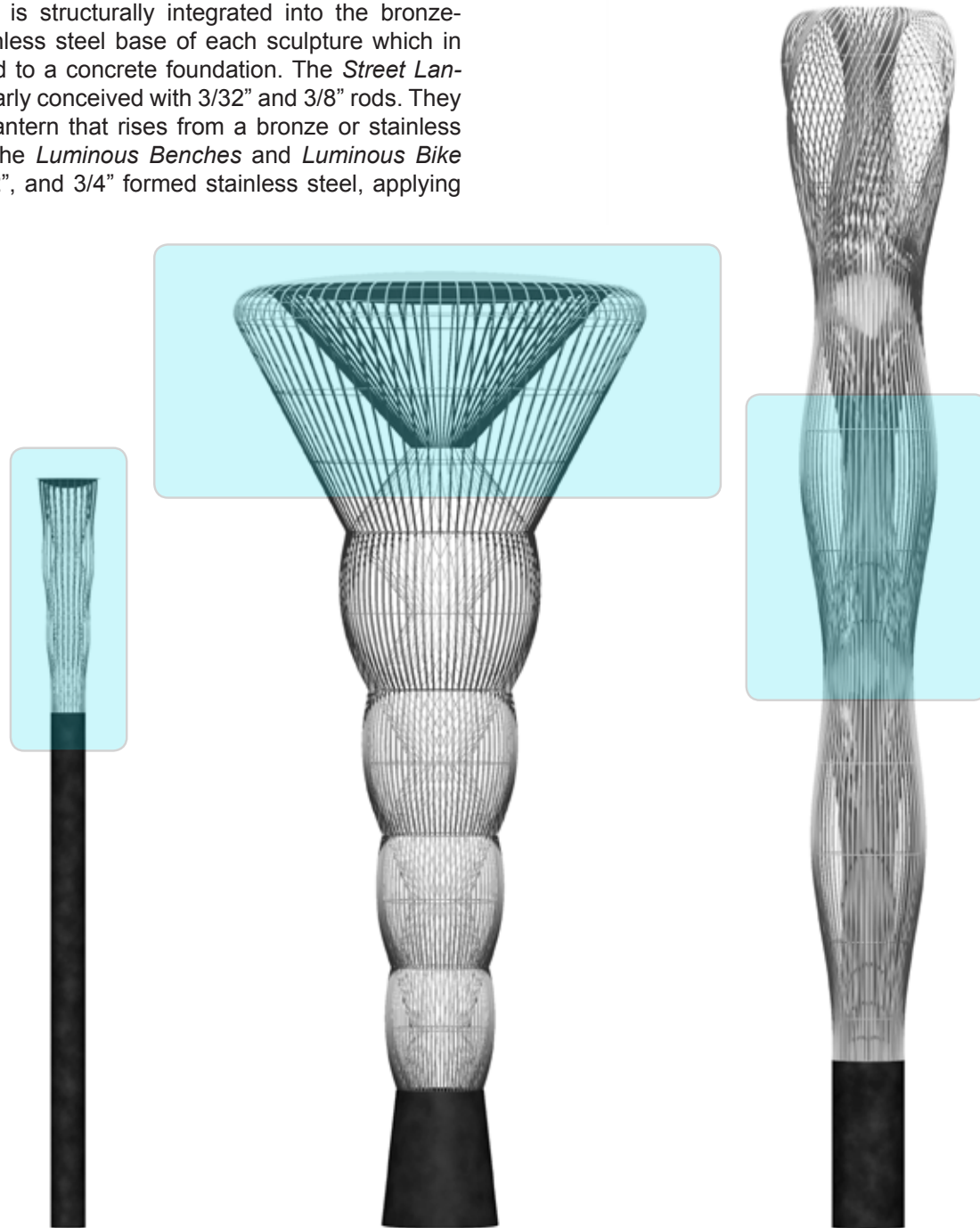



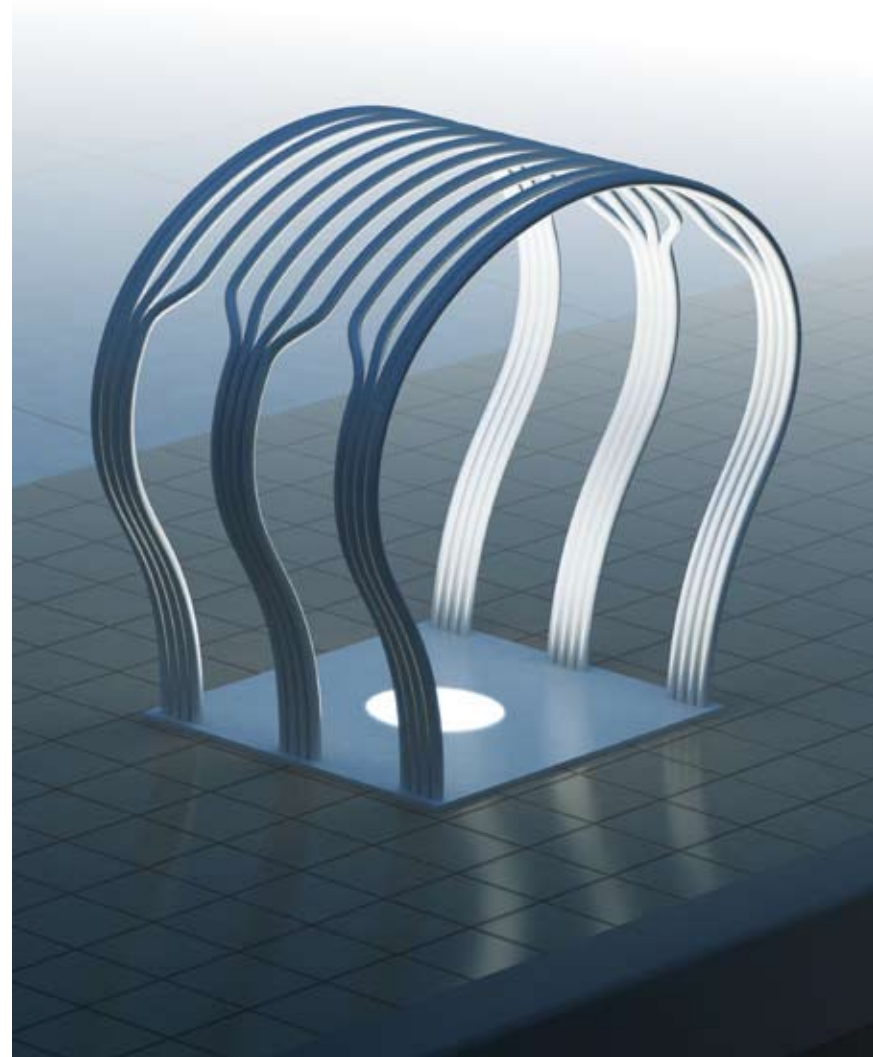

Self-illuminated street furnishings contribute to a unified pedestrian experience. They allow small and large elements to act together to influence the image of the street.



As utilitarian objects they allow passersby to interact with the work beyond having a solely visual experience.

26' Luminous Body (stainless steel, bronze, LED lighting) marking the Lynn Street entrance to the plaza at Central Place- looking west  
Luminous Bench (stainless steel, wood, LED lighting) installed along the Lynn Street corridor



Public art is about our public life. Good public art is usually good urbanism and a good public art plan is also a good urban plan because a better looking city always equates to a better business and residential environment. *The Corridor of Light* will establish dramatic and memorable entries into Rosslyn connected by an engaging linear progression of illuminated sculptures. The conscious decision to clearly delineate and celebrate the public realm with sculptures that are integrated into Rosslyn's lighting infrastructure ex-

hibits a sophisticated urbanism. The decision demonstrates that good urban form is built around sculptures that make people think and feel because there exists the possibility of stimulating peoples' imagination, thereby defining an identity for Rosslyn. Over time the *Luminous Bodies* on Lynn Street will take on a life of their own. The *Corridor of Light* will become a part of the Rosslyn experience because it will merge with the activities of the neighborhood. A chain of illuminated sculptures capable of changing color, from the

Esplanade to Meade Street Bridge, will create a powerful imprint on the public's imagination. The *Luminous Bodies* that comprise the *Corridor of Light* are forms that are classically iconic yet egalitarian and open. They offer the possibility for Rosslyn to build a new image and identity that sets Rosslyn apart for its distinctive public art and innovative urban form.

Technical Specifications

- HOUSING:**  
Aluminum  
Powder coat grey finish  
IP66 rating (Dry, Wet, Damp)
- UNIT DIMENSIONS (L x W x H):**  
137mm (5.39") x 178mm (7.00") x 238mm (9.38")
- UNIT WEIGHT:**  
3.50 kg (7.71 lbs)
- LEADER CABLE:**  
1.83 m (6.0 ft.)  
High voltage, plenum rated
- SOURCE:**  
Selected High Performance 3-watt LED
- LIFE EXPECTANCY:**  
75,000+ hours
- BEAM SPREADS:**  
8, 24, 48, and 120 degree
- LENS:**  
Clear tempered glass
- COLOR RANGE:**  
16.7 million additive colors (DMX512 protocol)  
Independent red, green, and blue LEDs for a full range of smooth saturated colors
- FIXTURE POWER REQUIREMENTS:**  
24VDC
- FIXTURE OUTPUT:**  
84W
- POWER CONSUMPTION:**  
91W
- POWER SUPPLY:**  
Compatible illumivision power supplies: PS- 100, PS- 150, PS- 300, and PS- 600
- POWER SUPPLY INPUT VOLTAGE:**  
85-264VAC
- CONTROL INTERFACE:**  
DMX Addressable
- CONTROL SPECIFICATIONS:**  
Controlled by illumivision or approved third party DMX controllers
- OPERATING TEMPERATURE:**  
-22 deg. C to +55 deg. C (-7.6 deg. F to + 131 deg. F)

illumivision



Physical Dimensions

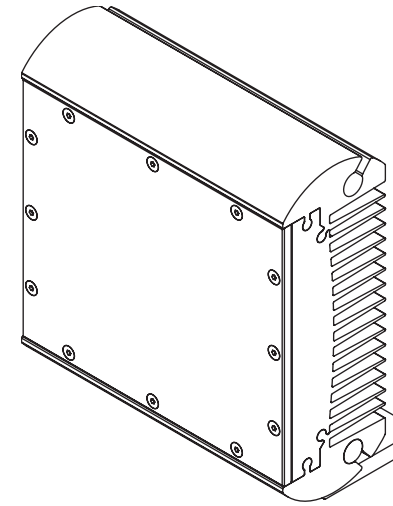

Isometric Elevation

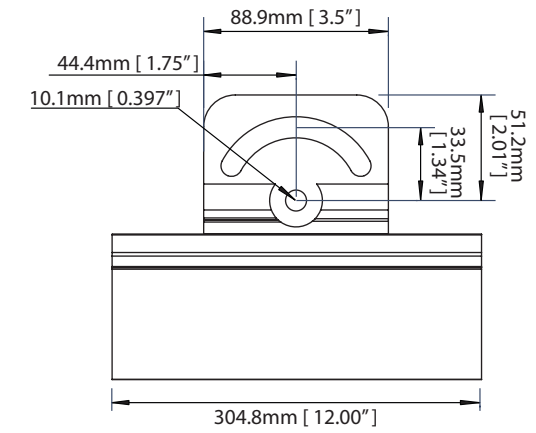

Top View

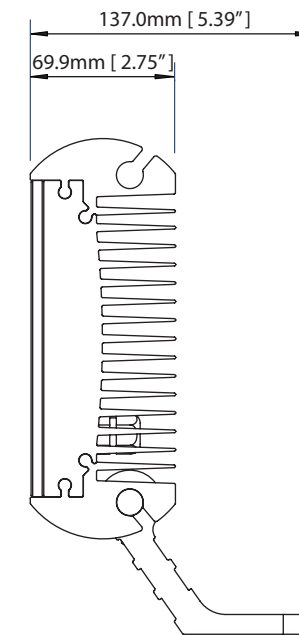

Side View

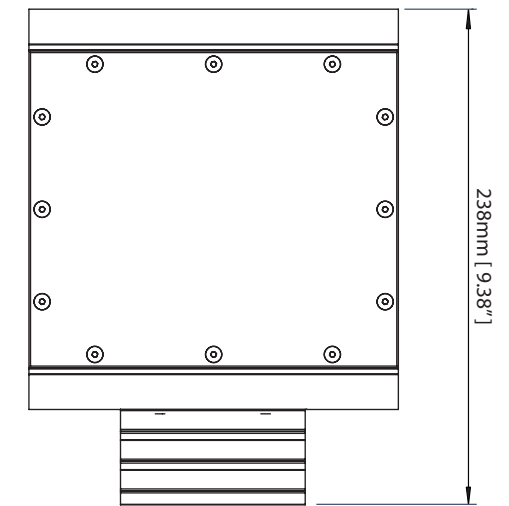

Front View

Technical Specifications

**HOUSING:**

Compression molded, fiber-reinforced polymer housing provides high strength and UV stability  
 Rated for cement, soil, and drive-over installations  
 Drive-over rating: 6000 PSI  
 Meets or exceeds UL, C-UL, CSA, and CE safety standards  
 Warranted against corrosion for 5-years

**HOUSING FINISH:**

Housing and standard slip-resistant composite lens retainer: Black  
 Optional aluminum accessories are available in Black or Clear polyester powder coat  
 Brass accessories have a natural cast finish

**HOUSING FASTENERS:**

All exposed fasteners are captive, black oxide coated, stainless steel

**UNIT DIMENSIONS (DIAMETER x HEIGHT):**

330.2 mm (13.34") x 431.8 mm (17.00")

**UNIT WEIGHT:**

10.43 kg (23 lbs)

**FIXTURE CONNECTORS:**

Weather proof data and power connectors

**SOURCE:**

Selected High Performance 3-watt LED

**LIFE EXPECTANCY:**

75,000+ hours

**COLOR TEMPERATURE:**

Adjustable and addressable  
 Available in the following monochrome options: red, green, blue, white, yellow, and amber

**COLOR RANGE:**

16.7 million additive colors (DMX512 protocol)  
 Independent red, green, and blue LEDs for a full range of smooth saturated colors

**BEAM SPREADS:**

8, 24, 48, and 120 degree

**LENS:**

Clear tempered glass lens on both fixture and housing

**FIXTURE POWER REQUIREMENTS:**

24VDC

**FIXTURE OUTPUT:**

84W  
 108W

**POWER CONSUMPTION:**

91W  
 120W

**POWER SUPPLY:**

Compatible illumivision power supplies: PS- 100, PS- 150, PS- 300, and PS- 600

**POWER SUPPLY INPUT VOLTAGE:**

85-264VAC

**CONTROL INTERFACE:**

DMX Addressable

**CONTROL SPECIFICATIONS:**

Controlled by illumivision or approved third party DMX controllers

**OPERATING TEMPERATURE:**

-22 deg. C to +55 deg. C (-7.6 deg. F to + 131 deg. F)

illumivision



Physical Dimensions

All dimensions are in millimeters (25.4mm = 1 inch)

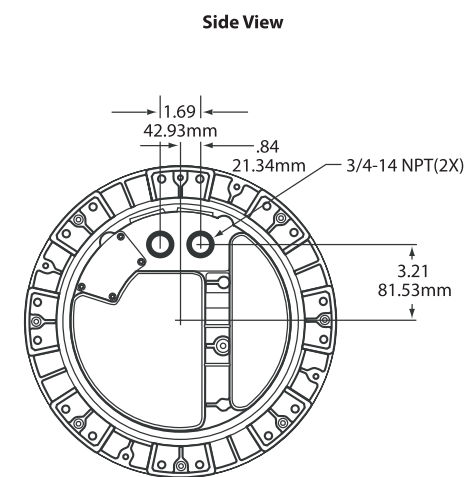
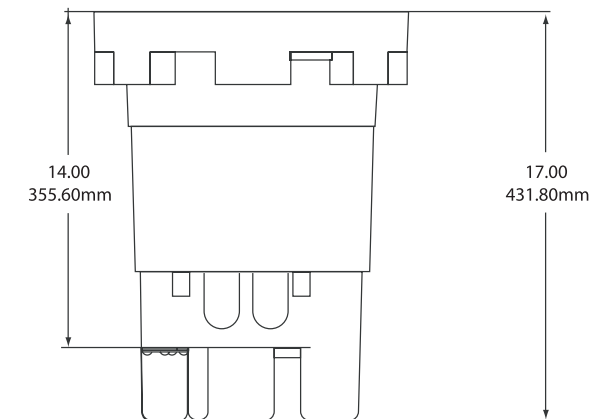
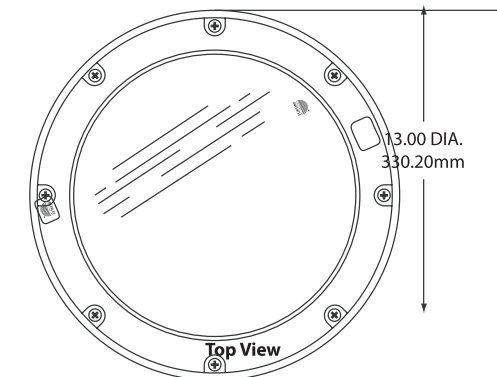

Inside Top View

Technical Specifications

**HOUSING:**

Aluminum  
Powder coat grey finish  
IP66 rating (Dry, Wet, Damp)

**UNIT DIMENSIONS (W x H):**

88.1mm (3.47") x 142.5mm (5.63")

**UNIT WEIGHT:**

0.96 kg (1.45 lbs)

**LEADER CABLE:**

1.83 m (6.0 ft.)  
High voltage, plenum rated

**SOURCE:**

Selected High Performance 3-watt LED

**LIFE EXPECTANCY:**

75,000+ hours

**BEAM SPREADS:**

8, 24, 48, and 120 degree

**LENS:**

Clear tempered glass

**COLOR RANGE:**

16.7 million additive colors (DMX512 protocol)  
Independent red, green, and blue LEDs for a full range of smooth saturated colors

**FIXTURE POWER REQUIREMENTS:**

24VDC

**FIXTURE OUTPUT:**

21W

**POWER CONSUMPTION:**

23W

**POWER SUPPLY:**

Compatible illumivision power supplies: PS- 100, PS- 150, PS- 300, and PS- 600

**POWER SUPPLY INPUT VOLTAGE:**

85-264VAC

**CONTROL INTERFACE:**

DMX Addressable

**CONTROL SPECIFICATIONS:**

Controlled by illumivision or approved third party DMX controllers

**OPERATING TEMPERATURE:**

-22 deg. C to +55 deg. C (-7.6 deg. F to + 131 deg. F)

illumivision



Physical Dimensions

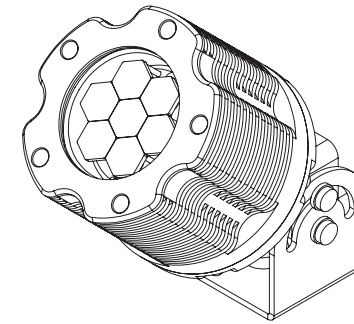

Isometric Elevation

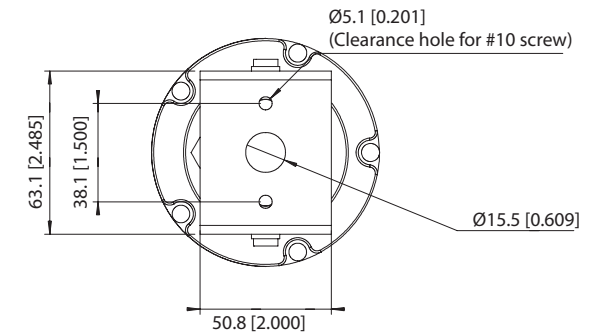

Mounting Bracket Detail

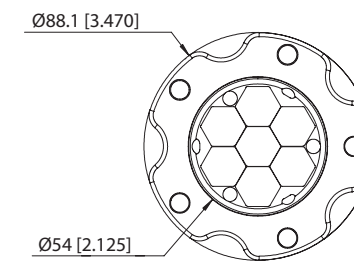

Top View

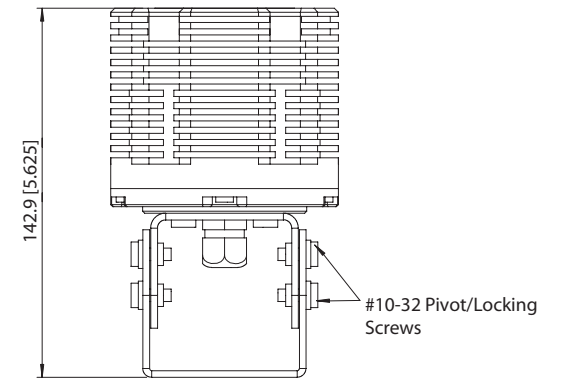

Side Elevation

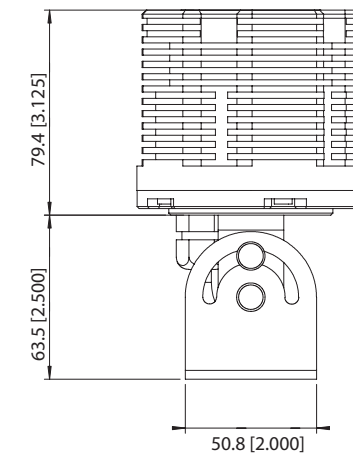

Side Elevation



